

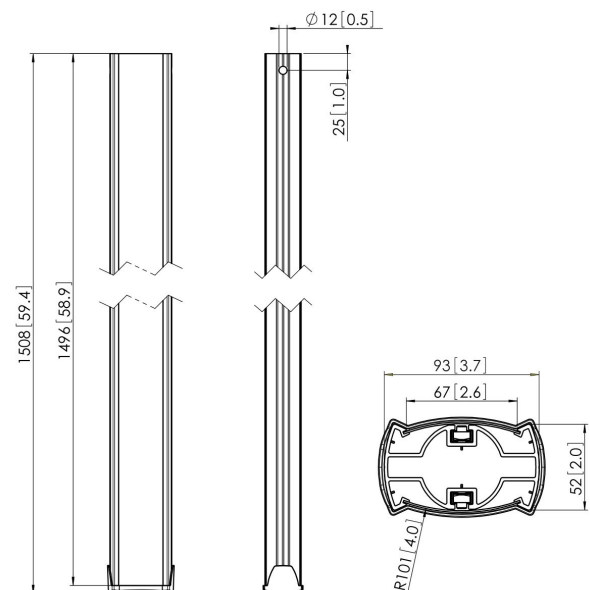

PUC 2515 Pole 150 cm silver

The PUC 2515 is a 150 cm pole and is a part of the modular Connect-it system with which you can create a ceiling solution for medium- to large-sized displays.





PUC 2515 Pole 150 cm silver



Specifications

<i>Article number (SKU)</i>	7225154
<i>Colour</i>	Silver
<i>EAN single box</i>	8712285318726
<i>Length</i>	1500
<i>TÜV certified</i>	Yes
<i>Guarantee</i>	5 years
<i>Max. weight load (kg)</i>	80
<i>Back-to-back displays</i>	True
<i>Connect It exceptions</i>	2x if inches gte 65

VOGEL'S HOLDING BV (c)

All rights reserved.
Subject to printing errors,
technical and price
amendments.

Date: 2022-02-11



Vogel's. For Sure.