

# Installation and Operation Guide

*It's Under Control®*

# CP-16i

Cool Power® Audio Amplifier





## FEDERAL COMMUNICATIONS COMMISSION NOTICE

This equipment has been tested and found to comply with the limits for a Class B digital device, pursuant to Part 15 of the FCC Rules. These limits are designed to provide reasonable protection against harmful interference in a residential installation. Any changes or modifications not expressly approved by the party responsible for compliance could void the user's authority to operate the device.

This equipment generates, uses, and can radiate radio frequency energy and, if not installed and used in accordance with the instructions, may cause harmful interference to radio communications. However, there is no guarantee that interference will not occur in a particular installation.

If this equipment does cause harmful interference to radio or television reception, which can be determined by turning the equipment off and on, the user is encouraged to try to correct the interference by one or more of the following measures:

- Reorient or relocate the receiving antenna.
- Increase the separation between the equipment and the receiver.
- Connect the equipment into an outlet on a circuit different from that to which the receiver is connected.
- Consult the dealer or an experienced radio/TV technician for help.

This device complies with Part 15 of the FCC Rules. Operation is subject to the following two conditions:

1. This device may not cause harmful interference.
2. This device must accept any interference received including interference that may cause undesired operation.

## Industry Canada Compliance Statement

This device complies with Industry Canada license-exempt RSS standard(s). Operation is subject to the following two conditions:

1. This device may not cause harmful interference.
2. This device must accept any interference received including interference that may cause undesired operation.

Cet appareil est conforme avec Industrie Canada exempts de licence standard RSS (s). Son fonctionnement est soumis aux deux conditions suivantes:

1. Ce dispositif ne peut causer des interférences nuisibles.
2. Cet appareil doit accepter toute interférence reçue y compris des interférences qui peuvent provoquer un fonctionnement indésirable.



## DECLARATION OF CONFORMITY (DOC)

The Declaration of Conformity for this product can be found on the RTI website at: [www.rticorp.com/declaration](http://www.rticorp.com/declaration)

### IMPORTANT SAFETY INSTRUCTIONS

**Read Instructions.** Read all safety and operating instructions before operating the unit.

**Retain Instructions.** Keep the safety and operating instructions for future reference.

**Heed Warnings.** Adhere to all warnings on the unit and in the operating instructions.

**Follow Instructions.** Install and operate in accordance with the manufacturer's instructions.

**Accessories.** Only use attachments/accessories specified by the manufacturer.

**Portable Cart Warning.** Use only with the cart, stand, tripod, bracket, or table specified by the manufacturer, or sold with the apparatus. When a cart is used, use caution when moving the cart/apparatus combination to avoid injury from tip-over.



**Heat.** Do not block any ventilation openings.

**Heat.** Keep the unit away from heat sources such as radiators, heat registers, stoves, etc., including amplifiers that produce heat.

**Power.** Unplug this apparatus during lightning storms or when unused for long periods of time.

**Power Sources.** Connect only to the power cord that was included with the unit.

**Power Outlet.** Do not overload wall outlets or extension cords beyond their rated capacity as this can cause electric shock or fire.

**Power Cord Protection.** Route power supply cords so that they are not likely to be walked on or pinched by items placed on or against them, paying particular attention to the cords at plugs, at convenient receptacles, and at the point at which they exit from the unit.

**Power Cord Grounding Plug.** Do not remove the grounding prong of the grounding-type plug. A grounding type plug has two blades and a third grounding prong. The third prong is provided for your safety. If the provided plug does not fit into your outlet, consult an electrician for replacement of the obsolete outlet.

**MAINS Outlet.** Where MAINS outlets are used, the apparatus shall be connected to a MAINS socket outlet with a protective earthing connection.

To completely disconnect this apparatus from the AC Mains, disconnect the power supply cord plug from the AC receptacle.

**MAINS Plug.** Where the MAINS plug or an appliance coupler is used as the disconnect device, the disconnect device shall remain readily operable.

**Water and Moisture.** Do not use the unit near water—for example, near a sink, in a wet basement, near a swimming pool, near an open window, etc.

**Object and Liquid Entry.** Do not allow objects to fall or liquids to be spilled into the enclosure through openings.

**Cleaning.** Clean only with dry cloth.

## **IMPORTANT SAFETY INSTRUCTIONS**

**Servicing.** Do not attempt any service beyond that described in the operating instructions. Refer all other service needs to qualified service personnel.

**Damage Requiring Service.** The unit should be serviced by qualified service personnel when:

- Objects have fallen or liquid has been spilled into the unit.
- The power supply cord or the plug has been damaged.
- The unit does not appear to operate normally or exhibits a marked change in performance.
- The unit has been dropped or the enclosure has been damaged.

**WARNING!**

**TO REDUCE THE RISK OF FIRE OR ELECTRIC SHOCK,  
DO NOT EXPOSE THE UNIT TO RAIN OR MOISTURE.**

### LIMITED WARRANTY

Remote Technologies Incorporated warrants its products for a period of three (3) years from the date of purchase from Remote Technologies Incorporated or an authorized Remote Technologies Incorporated distributor.

This warranty may be enforced by the original purchaser and subsequent owners during the warranty period, so long as the original dated sales receipt or other proof of warranty coverage is presented when warranty service is required. Except as specified below, this warranty covers all defects in material and workmanship in this product. The following are not covered by the warranty:

Damage resulting from:

1. Accident, misuse, abuse, or neglect.
2. Failure to follow instructions contained in this Guide.
3. Repair or attempted repair by anyone other than Remote Technologies Incorporated.
4. Failure to perform recommended periodic maintenance.
5. Causes other than product defects, including lack of skill, competence or experience of user.
6. Shipment of this product (claims must be made to the carrier).
7. Being altered or which the serial number has been defaced, modified or removed.

Remote Technologies Incorporated is not liable for any damages caused by its products or for its failure of its products to perform, including any lost profits, lost savings, incidental damages, or consequential damages.

Remote Technologies Incorporated is not liable for damages based upon inconvenience, loss of use of the product, loss of time, interrupted operation, commercial loss, any claim made by a third party or made by you for a third party.

Remote Technologies Incorporated's liability for any defective product is limited to repair or replacement of the product, at our option.

If any component of your CP-16i Audio Amplifier needs service, please contact Remote Technologies Incorporated by telephone or E-mail for return information.

**Please do not return products to Remote Technologies Incorporated without return authorization.**

### DISCLAIMER

All rights are reserved. No part of this document may be photocopied, reproduced, or translated without the prior written notice of Remote Technologies Incorporated.

The information contained in this document is subject to change without notice.

Remote Technologies Incorporated shall not be liable for errors or omissions contained herein or for consequential damages in connection with the furnishing, performance, or use of this guide.

CP-16i, Integration Designer, and the RTI logo are registered trademarks of Remote Technologies Incorporated.

Other brands and their products are trademarks or registered trademarks of their respective holders.

iPod, iPod classic, iPod nano, and iPod touch are trademarks of Apple Inc., registered in the U.S. and other countries.

## **TABLE OF CONTENTS**

<b>Federal Communications Commission Notice.....</b>	<b>3</b>
<b>Safety Suggestions.....</b>	<b>4</b>
<b>Limited Warranty .....</b>	<b>6</b>
<b>Disclaimer .....</b>	<b>6</b>
<b>Table of Contents .....</b>	<b>7</b>
<b>Chapter 1 - Welcome.....</b>	<b>8</b>
- Important Notes .....	8
- Product Contents .....	9
<b>Chapter 2 - Features and Description .....</b>	<b>10</b>
- Front Panel .....	10
- Rear Panel .....	11
<b>Chapter 3 - Installation and Operation .....</b>	<b>12</b>
- Controlling the CP-16i.....	12
- Mounting .....	12
- Wiring and Connections .....	13
- I/O Control Input Port.....	18
- Powering the CP-16i .....	23
<b>Chapter 4 - Specifications.....</b>	<b>24</b>
<b>Chapter 5 - Service and Support.....</b>	<b>26</b>

### CHAPTER 1 | WELCOME

#### **Thank you for using the CP-16i Cool Power® Audio Amplifier.**

Ideal for the discerning listener, the CP-16i Audio Amplifier utilizes Cool Power® technology for superb sonic performance. Featuring 16 channels of audiofile-grade sound, the powerful amplifier delivers 100 watts per channel, easily expanding the entertainment reach of any audio distribution system. For additional boost, bridge-mode is available, doubling the output to an incredible 200 watts per channel. Engineered to perform as well as it sounds, the CP-16i utilizes highly-efficient Class-D amplifier technology and has a compact chassis design that requires only one (1RU) rack space.

RTI amplifiers enhance the listening experience, delivering crystal clear, high quality sound to every room. Matched with the RTI control ecosystem, you have a complete solution for distributed audio in residential and commercial spaces. Go ahead and put RTI technology to the test - you'll never miss a beat.

#### **IMPORTANT NOTES**

Please read these important notes about the CP-16i:

- The CP-16i should be placed in an area where it is around normal room temperature (between 60°F to 90°F).
- Avoid installing the CP-16i in a location with little or no air circulation.
- Avoid installing the CP-16i in a location where it can come in contact with direct sunlight.
- Do not let the CP-16i system get wet. It should not be handled with wet hands or placed in an area where it could get wet.
- Do not subject the CP-16i to smoke, dust, or vibrations.
- Only use the power cord that is supplied with the CP-16i. Using the wrong type of power cord may result in damage.
- Do not disassemble the unit. Service of the CP-16i should be performed by authorized personnel only.



## **CHAPTER 1 | PRODUCT CONTENTS**

Contents within the box include the following items:

- One (1) CP-16i Cool Power® Audio Amplifier
- One (1) CP-16i Faceplate
- Two (2) Rack Mounting Ears with Screws
- Four (4) Feet with Screws
- Eight (8) Speaker Terminal Blocks
- One (1) IO Port Terminal Block
- One (1) Power Cord
- One (1) Installation Guide

### **UNPACKING AND INSPECTION**

After unpacking the CP-16i Audio Amplifier, save all of the packing materials in case you ever have to ship the unit.

Thoroughly inspect the CP-16i and packing materials for signs of damage. Report any damage to the carrier immediately. Report any equipment malfunctions to RTI or an authorized RTI distributor.

## CHAPTER 2 | FEATURES AND DESCRIPTION

### FEATURES

- **Superior Performance** – Utilizes proven audio amplification technology to deliver premium sonic performance.
- **Easy Expansion** – 16 channels available for all kinds of zoning configurations in large or far reaching the properties.
- **Power & More Power**– 100 watts per channel at 4 ohms / 200 watts at 8 ohms bridged.
- **Compact Design** – At just 1RU high, the CP-16i leaves room to install more components in the rack.
- **Ultra-Efficient** – Cool Power® Class D amplifier technology ensures efficient heat dissipation and low power consumption.

### NOTES:

- Note that the CP-16i requires an external preamp for volume control.
- The CP-16i also supports a Bridge Mode (BTL) configuration. Bridge Mode converts one stereo pair into a single, stronger amplification channel. If all Zones are bridged, there are 8 channels available. Stereo and Bridged Zones can be mixed as necessary.

### Front Panel Components (LEDs)

The front panel features three LEDs.



### POWER LED (Green/Red)

The Power LED indicates that the current power state of the amp:

- Green indicates that the amplifier is On.
- Red indicates that the amplifier is receiving power, but is in Standby mode.

### OC/CLIP LED (Yellow/Red)

The OC/CLIP LED indicates that either the current of one or more of the speaker outputs has exceeded its maximum or that the power supply is overloaded.

**NOTE:** The amplifier outputs are limited to 20A peak each in order to protect the power stages against overload during a short circuit, or over-current event on the output of the amplifier.

- Yellow indicates an OC (over-current) shutdown of the amplifier output. In the case of an OC event, the amplifier will shut down to protect itself, and indicate an OC event on this LED (yellow) and the OC pin (pin 8 on the 10-pin I/O port - see page 15). An OC event can indicate a cable fault, installation fault or defective speaker.

## CHAPTER 2 | FEATURES AND DESCRIPTION

- Red indicates an overload event with the Power Supply. The LED will light red if internal temperature sensors on the power supply sense an abnormally high temperature, or if power supply over-current/over-load/power-limit circuits are triggered. In either case, the power supply will limit the amplifier output to keep the power supply within safe limits, while keeping the music playing.

### THERMAL LED (Red)

The Thermal Protection LED indicates thermal shutdown of the individual zones (amplifier boards).

- The temperatures of all the output channels are individually monitored, and if one or more of them reaches the thermal limit (105°C) then the respective Zones will shut down and go into soft start mode (Channels 1/2 = Zone 1, Channels 3/4 = Zone 2, etc), and the Thermal Protection LED will be lit.
- The other Zones will continue to be active. When the temperature has dropped below the thermal threshold, the respective Zone(s) start up again automatically.

### CP-16i REAR PANEL COMPONENTS

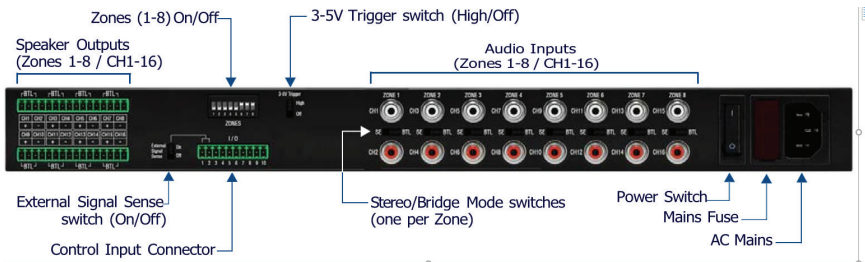

### CHAPTER 3 | INSTALLATION AND OPERATION

#### Controlling the CP-16i

The CP-16i can be powered on and off externally by using the two signals 12V trigger and 3-5V trigger. A Signal Sense function is also provided which automatically can switch on the CP-16i in the event of an audio signal and switch off the CP-16i to enter standby mode when no audio signal has been present on the signal terminals for approximately 13 minutes.

NOTE: Volume control for the CP-16i is managed by an external pre-amp or audio switcher.

#### Installation

##### Mounting the CP-16i into an Equipment Rack

The CP-16i can be mounted in a 19" equipment rack or on a solid flat surface. Use the included removable rack ears and removable feet for mounting.

#### Ventilation

**NOTE:** The maximum operating ambient temperature is 45°C (113°F).

- To ensure that the rack enclosure is adequately ventilated, there must be a minimum of 3" all around the CP-16i unit.
- Sufficient airflow must be achieved (by convection or forced-air cooling) to satisfy the ventilation requirements of all the items of equipment installed within the rack.

#### Rack Mount Safety Instructions

- Mounting of the equipment in the rack should be such that a hazardous condition is not achieved due to uneven mechanical loading.
- Consideration should be given to the connection of the equipment to the supply circuit and the effect that overloading of the circuits might have on over current protection and supply wiring. Appropriate consideration of equipment nameplate ratings should be used when addressing this concern.
- Reliable grounding (earthing) of rack-mounted equipment should be maintained. Particular attention should be given to supply connections other than direct connections to the branch circuit (e.g. use of power strips).

## CHAPTER 3 | INSTALLATION AND OPERATION

### Wiring and Connections

**IMPORTANT NOTE:** The amplifier must be turned off whenever you make changes to the input connections and speaker wire connections.

#### Connecting Audio Source Devices

Source Devices connect to the Audio (Signal) Inputs connectors on the rear panel.

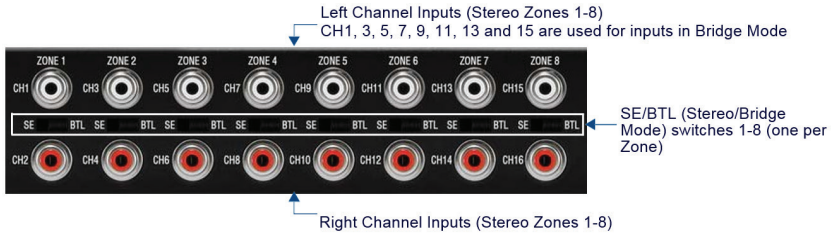

#### Audio (Signal) Inputs

The following table provides pinout information for the Audio Inputs:

Audio Input Connectors - Pinout Information			
PIN	Function	Description	Type
1	Signal +	Single Ended Signal Positive	Input
2	Signal GND	Single Ended Signal GND	GND

#### SE/BTL (Stereo/Bridge Mode) Switches (1-8)

Eight **SE/BTL** slide switches (located between the two RCA/phono input connectors for each Zone). These switches provide the ability to set each of the eight Zones to either Stereo Mode (SE) or Bridge Mode (BTL). Note that by default, all Audio Inputs are set to Stereo Mode.

- **Stereo Mode (SE):** In Stereo Mode, both channels are used for stereo audio input. Stereo mode provides true stereo separation between the left and right channels in each Zone.
- **Bridge Mode (BTL):** Bridge Mode uses one input channel of the amplifier to combine the power from both channels output into one single output. In Bridge Mode, the odd channels are used for audio input and the even channels are disconnected internally.

### CHAPTER 3 | INSTALLATION AND OPERATION

#### Connecting Input Devices in Stereo Mode

Stereo input devices use both input channels (left and right) for each Zone.

- **Odd**-numbered channels (with white connectors) should be used to connect to the left output on the source device.
- **Even**-numbered channels (with red connectors) should be used to connect to the right output on the source device.

The CP-16i supports up to eight stereo input devices, each one associated with an input Zone (1-8). Note that each Zone represents a stereo pair. For example, Zone 1 consists of CH1 (left channel) and CH2 (right channel).

There is a direct correlation between the audio inputs and the speaker outputs. For example, a stereo device connected to the Zone 1 inputs (CH1 and CH2) will output on the CH1 (left) and CH2 (right) speaker outputs:

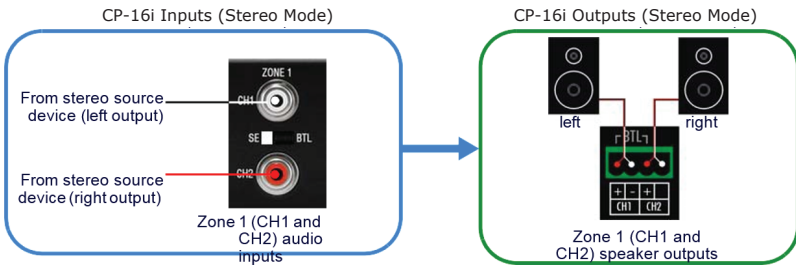

**NOTE:** When connecting stereo input devices, verify that the Stereo/Bridge (SE/BTL) mode switch for the Zone is set to "SE". This is the default factory setting.

#### Connecting Input Devices in Bridge Mode

In Bridge Mode, input devices connect to the left input channels only. Note that left input connectors are white, and are the odd-numbered channels (CH1, 3, 5, 7, 9, 11, 13 and 15).

There is a direct correlation between the audio inputs and the speaker outputs. For example, a bridged device connected to the Channel 1 input (CH1) will output on the CH1 (left) and CH2 (right) speaker outputs:

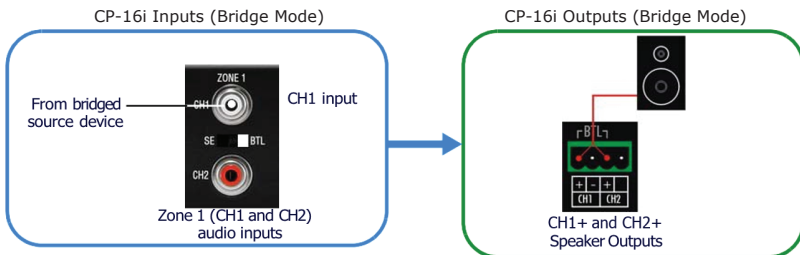

**NOTE:** When connecting bridged input devices, verify that the Stereo/Bridge (SE/BTL) mode switch for the Zone is set to "BTL" as shown above

## CHAPTER 3 | INSTALLATION AND OPERATION

### Connecting Speakers

All speaker connections must use Class 2 Wiring. Class 2 Wiring is required due to the fact that power is above 10W per channel under normal operating conditions.

Speakers connect to the captive-wire output terminals (CH1-CH16) on the rear panel:

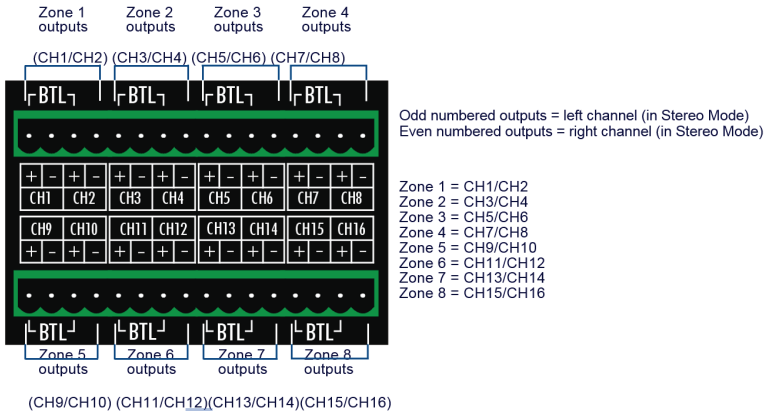

Each Zone (1-8) consists of two channels (an L/R pair in Stereo Mode), and each Channel (1-16) uses a 2-pin captive-wire connector to connect to speakers.

**NOTE:** For wiring runs longer than 80 feet, 14-gauge speaker wire is recommended.

### Speaker Output Connectors

The speaker output connectors consist of two 16 pin captive-wire terminals; each of the output terminals having a "+" and "-" terminal.

The label "BTL" on each speaker pair points to the pins that are used when connecting a single speaker to an input in Bridge Mode.

The following table provides pinout information for the Speaker Output Terminals

#### Speaker Output Terminals Pinout Information

PIN	Function	Description	Type
1	OUT+	Positive balanced audio power output terminal	Output
2	OUT-	Negative balanced audio power output terminal	Output

### CHAPTER 3 | INSTALLATION AND OPERATION

#### Connecting Speakers in Stereo Mode

**NOTE:** When connecting stereo speakers, verify that the Stereo/Bridge (SE/BTL) mode switch for the associated Zone is set to “SE”.

Stereo speaker pairs use both output channels (left and right) for each Zone.

- **Odd**-numbered channels should be used to connect to the left speaker.
  - **Even**-numbered channels should be used to connect to the right speaker.
- The CP-16i supports up to eight stereo speaker pairs, each one associated with a Zone (1-8). This diagram illustrates the wiring connection from both Zone output channels to a stereo speaker pair:

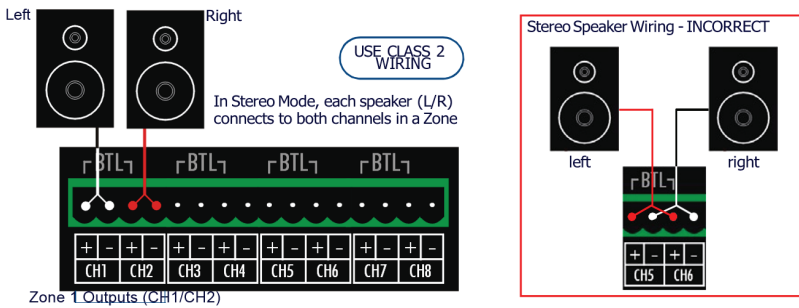

**NOTE:** If incorrect wiring is used there is a risk of electrical shock and a fire hazard.

The table below illustrates the direct correlation between the audio inputs and the speaker outputs in Stereo Mode:

Audio Inputs to Speaker Outputs - Stereo Mode		
Zone	Audio Input Connectors	Speaker Output Connectors
1	CH1 (left) / CH2 (right)	CH1 (left) / CH2 (right)
2	CH3 (left) / CH4 (right)	CH3 (left) / CH4 (right)
3	CH5 (left) / CH6 (right)	CH5 (left) / CH6 (right)
4	CH7 (left) / CH8 (right)	CH7 (left) / CH8 (right)
5	CH9 (left) / CH10 (right)	CH9 (left) / CH10 (right)
6	CH11 (left) / CH12 (right)	CH11 (left) / CH12 (right)
7	CH13 (left) / CH14 (right)	CH13 (left) / CH14 (right)
8	CH15 (left) / CH16 (right)	CH15 (left) / CH16 (right)



## CHAPTER 3 | INSTALLATION AND OPERATION

### Connecting Speakers in Bridge Mode

**NOTE:** When connecting a speaker to a “bridged” input, verify that the Stereo/Bridge (SE/BTL) mode switch for the associated Zone is set to “BTL”.

In Bridge Mode, both channels in a Zone are connected to a single speaker, via the positive (“+”) pins for both output channels:

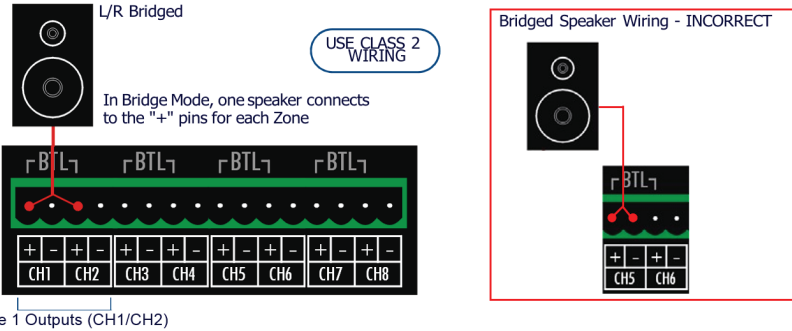

Zone 1 Outputs (CH1/CH2)

**NOTE:** If incorrect wiring is used there is a risk of electrical shock and a fire hazard.

The table below illustrates the direct correlation between the audio inputs and the speaker outputs in Bridge Mode:

Audio Inputs to Speaker Outputs - Bridge Mode		
Zone	Audio Input Connectors	Speaker Output Connectors
1	CH1 (left)	CH1 (+) / CH2 (+)
2	CH3 (left)	CH3 (+) / CH4 (+)
3	CH5 (left)	CH5 (+) / CH6 (+)
4	CH7 (left)	CH7 (+) / CH8 (+)
5	CH9 (left)	CH9 (+) / CH10 (+)
6	CH11 (left)	CH11 (+) / CH12 (+)
7	CH13 (left)	CH13 (+) / CH14 (+)
8	CH15 (left)	CH15 (+) / CH16 (+)

## CHAPTER 3 | INSTALLATION AND OPERATION

### I/O (Control Input) Port

The 10-pin captive-wire I/O (Control Input) port is for external control and status indication.

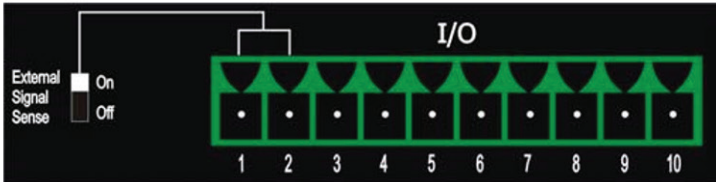

10-pin I/O (Control Input) Port with External Signal Sense switch

The following table lists the pinouts for the I/O port

10-Pin I/O Port - Pinout Information			
PIN	Function	Description	Type
1	Signal Sense +	Signal Sense	Input
2	Signal GND	Single Ended Signal GND	GND
3	12V Trigger In	12V Trigger Input	Input
4	Trigger Loop Out	Trigger Loop Out	Output
5	GND	Logic / Trigger GND	GND
6	3-5V Trigger	Logic Level Trigger	Input
7	Thermal	Thermal Overload Indicator	Output
8	OC	Overcurrent Monitor Indicator	Output
9	On signal	On Signal Output	Output
10	GND	Status GND	GND

## CHAPTER 3 | INSTALLATION AND OPERATION

The function of each pin on the I/O port is described below.

### Pin 1 - Signal Sense

Pin 1 on the 10-pin I/O port is used for single-ended Signal Sense input (+). This pin detects an input signal from a source device when the source device is active. Pin 1 (Signal Sense +) connects to one of the source device's input cables to provide a signal to the CP-16i when the source device is active.

### Pin 2 - Signal Sense Input Ground

Pin 2 on the 10-pin I/O port is used for Signal Sense input ground (-).

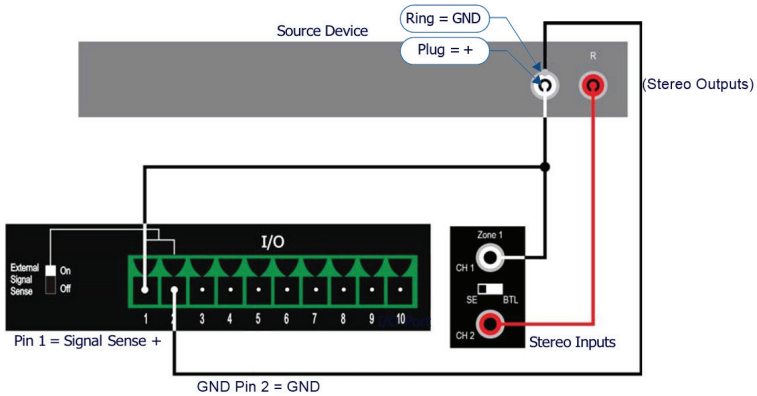

PIN 1 Example - Signal Sense Connection (Unbalanced)

### External Signal Sense Switch

With the External Signal Sense switch in the ON position, the amplifier is automatically turned on when an audio signal is present, and automatically placed in standby mode when no audio signal has been present on the signal terminals for approximately 13 minutes.

- Note that the example diagram indicates the Signal Sense connection tied to the Left output from the source device, but Signal Sense can come from either output.
- The amplifier will power up if a signal is applied to the signal sense input. By default, the External Signal Switch is set to the ON position.

### Pin 3 - 12V (In) Trigger

The CP-16i can be turned On or placed in Standby mode externally via a 12V Trigger signal. A 12V trigger input is accessible via Pin 3 on the 10-pin I/O port.

### CHAPTER 3 | INSTALLATION AND OPERATION

#### Pin 4 - Trigger (Loop Out)

The CP-16i also provides a convenient way to daisy-chain a 12V trigger to other devices. Any voltage provided to Pin 3 is looped out to Pin 4 of the 10-pin I/O port:

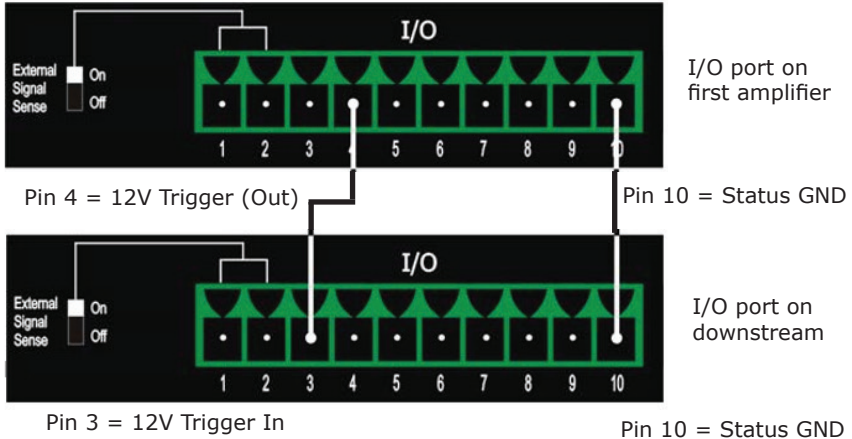

PIN 4 Example - Trigger (Loop Out) Connections

Pin 4 connects to a +12V Trigger (input) on a downstream amplifier

**NOTE:** Pin 3 and Pin 4 are hard wired together. Therefore, when a trigger is applied to pin 3 it will also be present at pin 4. Pin 4 will be high only if a signal is applied to Pin 3.

#### Pin 5 - Local/Trigger GND

Pin 5 on the 10-pin I/O port provides a ground connection for the 3-5V Logic Level Trigger. Pin 5 connects to the GND pin of an I/O port on an external controller.

#### Pin 6 - 3-5V Logic Level Trigger

The CP-16i can be also turned On or placed in Standby mode externally via a 3-5V Logic Level trigger signal. A 3-5V trigger input is accessible via Pin 6 on the 10-pin I/O port.

#### 3-5V Trigger Switch

The 3-5V Trigger Switch has two selections; High and Off.

When the 3-5V Trigger Switch is set to High, the amplifier will turn on when AC mains is turned on. For example, the 3-5V Trigger switch could be set to High if the amplifier needs to be forced on without having signal sense or external trigger signals.



## CHAPTER 3 | INSTALLATION AND OPERATION

### Pins 7 & 8 - Thermal Overload and OC (Overcurrent) Monitor Indicators

The Thermal Overload Indicator (OUT) signal can be used to send a Thermal message from the CP-16i to an external controller if desired.

The OC (Overcurrent) Monitor Indicator (OUT) signal can be used to send an OC message from the CP-16i to an external controller if desired.

**NOTE:** The THERMAL and OC/CLIP LEDs on the front panel always light to indicate these conditions.

- A Thermal Overload Indicator signal is output on Pin 7 on the 10-pin I/O port. This pin connects to an I/O pin on an external controller.
- An Overcurrent Monitor Indicator signal is output on Pin 8 on the 10-pin I/O port. This pin connects to an I/O pin on an external controller such.

### Pin 9 - On Signal Output / 12V Trigger

#### On Signal Output

Pin 9 on the 10-pin I/O port provides a continuous 12VDC when the CP-16i exits Standby Mode for On. When the CP-16i is in Standby mode, Pin 9 voltage falls to zero. When connected to an external Controller, this pin allows the Controller to be aware of the On/Off state of the CP-16i.

For Signal Output, Pin 9 connects to an I/O pin on an external controller.

#### 12V Trigger

Pin 9 also functions as a 12V on/off output trigger. In this case, it can be used to turn on or off other amplifiers, when there are multiple CP-16i system in an installation.

As a 12V Trigger, Pin 9 connects to Pin 3 (12V Trigger Input) on a downstream CP-16i.

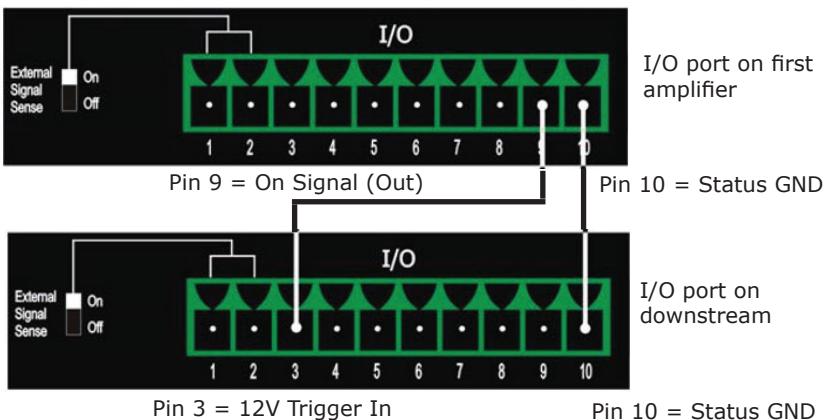

## CHAPTER 3 | INSTALLATION AND OPERATION

### Pin 10 - Status GND

Pin 10 on the 10-pin I/O port provides a ground reference for the Output pins (7-9), and is required for any device that needs to sense the potential.

Pin 10 connects to the GND pin of an I/O port on an external controller.

### On/Off Control (12V Trigger, 3-5V Trigger and Signal Sense)

The CP-16i can be powered on and off externally by using the two signals 12V trigger and 3-5V trigger. A Signal Sense function is also provided which automatically can switch on the CP-16i in the event of an audio signal and switch off the CP-16i to enter standby mode when no audio signal has been present on the signal terminals for approximately 13 minutes. The Signal Sense function consists of an audio detection circuit and a timer. If an audio signal of more than typically 1.3mVrms is present on the Signal Sense terminals, the CP-16i will always be in the On mode. If none of the two triggers are high and audio is not present at the terminals the timer will switch off the CP-16i after 13 minutes.

**NOTE:** Pins 1 and 2 on the 10-pin I/O port provide Signal Sense (+ and -) inputs.

**NOTE:** When changing control signals from on mode to standby mode, there is a 200ms delay before the main SMPS turns off. This is to provide time for internal circuitry to power down in order to meet the standby mode current draw requirements.

### Enabling and Disabling Zones

The 8-position dip switch labeled "ZONES" provides the ability to individually enable or disable any of the 8 Zones. It is recommended to disable Zones that are not being used, to lower power consumption.

To disable a Zone, flip the associated switch (1-8) from Enable (default setting) to Disable.



ZONES Dip Switch

The UP position enables each Zone; the Down position enables each Zone.

## CHAPTER 3 | INSTALLATION AND OPERATION

### Applying Power to the CP-16i Amplifier

**CAUTION:** This unit should only have one source of incoming power. Using more than one source of power to the CP-16i can result in damage to the internal components and a possible burn out.

**CAUTION:** Apply power to the unit only after installation is complete.

### AC Power Plug Connector

The following table provides pinout information for the AC Connector:

AC Power Plug Connector - Pinout Information			
PIN	Function	Description	Type
1	Live	Mains AC Live	Input
2	Neutral	Mains AC Neutral	Input
3	PE	Protective Earth	Input

- Mains Power Fuse - T6.3A H Mains Power Fuse fuse provides over-current protection.
  - Mains Power Switch - The power switch is the AC mains switch, which turns everything off when it is in the Off position, and powers everything on when it is in the On position.
1. Connect a standard IEC 3-pole detachable power cord to the AC Mains power connector on the rear panel.
  2. Plug the attached power plug into a correctly grounded wall outlet.
  3. Switch the Mains Power Switch (on the rear panel) to the On position.

Note that the POWER LED on the front panel lights Green to indicate that the amplifier is receiving power (and not in Standby mode).

### Entering Standby Mode

To put the CP-16i Amplifier in Standby Mode:

- Remove signal from the signal sense input, or disable signal sense input. See the Pin 1 - Signal Sense section on page 15 for details.
- Enable 3-5V trigger -> Disable 3-5V trigger

Note that the POWER LED on the front panel lights Red to indicate that the amplifier is receiving power, but is in Standby mode. Also note that when in Standby mode, the 12V output trigger is turned off.

### CHAPTER 4 | SPECIFICATIONS

#### GENERAL

Height	1U, 1.7 inches/44 mm (1 RU)
Width	16.7 inches (424mm) - Fits in a standard 19" equipment rack
Depth	8.98" (228mm) without connectors and 9.30" (236.3mm) with connectors
Weight	10.98 lbs (4.1kg)
Warranty	Three Years (Parts & Labor)

#### AUDIO

Number of channels	16 channels in 8 stereo Zones; each Zone can be bridged.
Output power	<ul style="list-style-type: none"> <li>100W per Ch. in SE, 4Ω (1%THD+N, 20Hz - 20kHz)</li> <li>200W per Ch. in BTL, 8Ω (1%THD+N, 20Hz - 20kHz)</li> </ul>
Amplifier	<ul style="list-style-type: none"> <li>Amplifier Gain: The audio gain (20Hz to 20kHz) is 25.8dB ±0.5dB.</li> <li>Amplifier Input: The amplifier has a Single Ended input. Maximum input voltage without clipping is 1Vrms.</li> <li>Amplifier Output: The amplifier uses a Single Ended output stage. Thus the power output is GND referenced.</li> </ul> <p>Maximum output voltage without clipping is 28Vp.</p>
THD + N	1%, 4Ω, SE, f=100Hz, Po=1W
Dynamic range	110dBA SE, 115dBA BTL
Idle noise	50uV, A-weighted, 20Hz-20kHz
Upper bandwidth, -3 dB	<ul style="list-style-type: none"> <li>100 kHz, 4Ω, SE</li> <li>120 kHz, 8Ω, SE</li> </ul>
Frequency response	±0.4 dB, 10Hz- 20kHz, all loads
Input impedance	47K Ω
Output serial impedance	30m Ω, f≤1kHz



## CHAPTER 4 | SPECIFICATIONS

### POWER

AC mains power	Universal Mains 100-240VAC, 50-60Hz
Fuse rating	T6.3A_H 250V
Power connection	IEC 320 C13 power connector with 3-pole detachable power cord
Standby power consumption	Less than 0.25W
Control	Audio input sense, 12V trigger and 3-5V trigger

### THERMAL

Environmental operating temperature	32° - 113°F/ 0° - 45°C
Thermal dissipation	Two low noise fans mounted in side panels
Thermal dissipation (heat losses)	<ul style="list-style-type: none"> <li>• 0.23 W/ 0.8 BTU/hr, standby</li> <li>• 40 W/ 136.5 BTU/hr, idle, all ch.</li> <li>• 100 W/ 341 BTU/hr, max output power, all ch. driven</li> </ul>

## CHAPTER 5 | SERVICE AND SUPPORT

### Contacting RTI

For news about the latest updates, new product information, and new accessories, please visit our web site at: [www.rticorp.com](http://www.rticorp.com)

For general information, you can contact RTI at:

**Remote Technologies Incorporated**  
**5775 12th Ave. E Suite 180**  
**Shakopee, MN 55379**  
**Tel. (952) 253-3100**  
**Fax (952) 253-3131**  
**info@rticorp.com**

### Service & Support

If you are encountering any problems or have a question about your RTI product, please contact RTI Technical Support for assistance (see the Contacting RTI section of this guide for contact details).

RTI provides technical support by telephone or e-mail. For the highest quality service, please have the following information ready:

- Your Name
- Company Name
- Telephone Number
- E-mail Address
- Product model and serial number (if applicable)

If you are having a problem with hardware, please note the equipment in your system, a description of the problem, and any troubleshooting you have already tried.

**\*Please do not return products to RTI without return authorization.\***



*It's Under Control®*



**Remote Technologies Incorporated**  
**5775 12th Avenue East, Suite 180**  
**Shakopee, MN 55379**  
**Tel: 952-253-3100**  
**Fax: 952-253-3131**  
**[www.rticorp.com](http://www.rticorp.com)**